

MFG Part #	Product Description	Fastening Requirements		Weight
		Type & Size	Total Per Tie Back	
HTB-ALT 16	16" Hardy Standard Tie Back	SDS Screw - 1/4" x 3"	24	95#
HTB-ALT 24	24" Hardy Standard Tie Back	SDS Screw - 1/4" x 3"	32	130#
HTB-ALT 32	32" Hardy Standard Tie Back	SDS Screw - 1/4" x 3"	40	150#
HTB-ALT-CM/FM	Hardy Cap Mount/ Flush Mount	SDS Screw - 1/4" x 3"	16	100#
HTB-ALT-T24	T 24" For Trusses 24" O.C.	SDS Screw - 1/4" x 3"	32	120#

FOOTNOTES:
1. FOR WOOD SPECIES WITH MINIMUM SPECIFIC GRAVITY OF 0.5, USE SDS PER SCHEDULE TO FILL ALL PROVIDED 5/16" DIAMETER HOLES.

INSTALLATION INSTRUCTIONS:

- INSTALL AFTER COMPLETION OF JOIST, TRUSSES AND RAFTERS
- BEST TO INSTALL DURING SHEATHING OR AFTER SHEATHING IS COMPLETE, MAKING IT EASIER TO DISTRIBUTE HTB-DEVICES ON ROOF.
- HTB-DEVICES ARE DESIGNED TO FIT WITHIN A STANDARD 16" JOIST LAYOUT. THE ROUGH OPENINGS ARE TO BE 14 1/2" x 19"
- SUPPORTS (BEAMS, TRUSSES) FOR THE HTB-DEVICE ARE TO BE DESIGNED BY EOR.
- SET HTB-DEVICE IN THE OPENING, FASTEN THE SKIRTS WITH SDS 3" X 1/4" PER SCHEDULE. HOLES ARE PROVIDED IN THE SKIRTS LOCATION.
- 5/16" HOLES ARE PROVIDED IN SKIRTS TO ALLOW ATTACHMENT OF STRUCTURAL MEMBERS TO HTB DEVICES - USE 1/4" X 3" SDS. USE ALL PROVIDED HOLES.

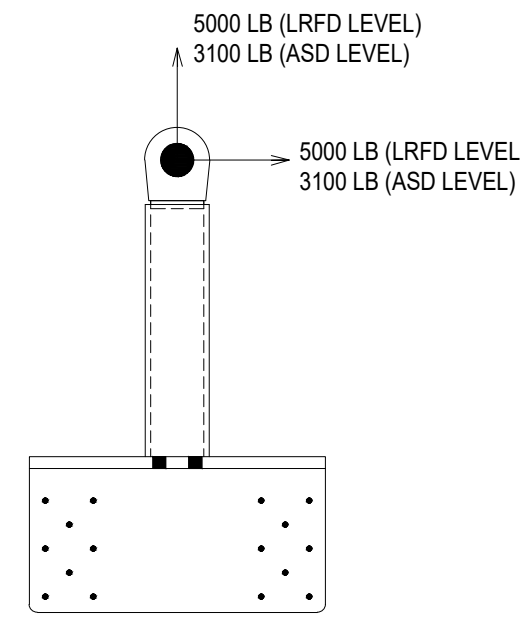

NOTE: PROPERTIES AND DIMENSIONS IN THIS DRAWINGS SHOW HTB-ALT-16
INSTALLATION OF HTB-24 AND HTB-32 IS SIMILAR

ANY QUESTIONS REGARDING INSTALLATION

CALL: GARY HARDY 1 (805) 404-5196 ANCHOR TESTING SHALL BE CONDUCTED BY QUALIFIED PERSONNEL UNDER THE SUPERVISION OF A PROFESSIONAL ENGINEER IN ACCORDANCE WITH THE CALIFORNIA CODE OF REGULATIONS, TITLE 8, SECTION 3296.

RECOMMENDATIONS

- DESIGN OF STRUCTURAL MEMBERS PER EOR
- STRUCTURAL SUPPORT ATTACHED TO TRUSSES TO BE DESIGNED BY EOR AND SHOULD HAVE ENOUGH LENGTH AND FASTENERS TO THE TRUSS TO ALLOW FOR FULL TRANSFER OF FORCES TO THE TRUSSES
- STRUCTURAL SUPPORT ATTACHED TO THE TRUSS IS RECOMMENDED TO BE OF ENGINEERED WOOD TO MINIMIZE SPLITTING

IAPMO UES ER 461, SECTION 3.2.2
3.2.2 ALLOWABLE STRESS DESIGN (ASD): IN COMPLIANCE WITH SECTION 4.6.5 OF ASCE 7-16, THE ASD LEVEL STRENGTH FOR THE HARDY ROOF TIE-BACK DEVICES IS 3,100 POUNDS (13.8 KN) MAXIMUM IN THE HORIZONTAL AND VERTICAL DIRECTIONS. THE EYEBOLT SHALL BE ORIENTED PARALLEL TO THE HORIZONTAL LOAD. WHEN PLACED ON AND FASTENED TO THE STRUCTURAL SUPPORTS, THE DEVICE SHALL BE DESIGNED TO DEVELOP THE 3,100 POUNDS (13.8 KN) ASD STRENGTH. FASTENING TO WOOD BASED ON CD = 1.5 IN ACCORDANCE WITH THE ANSII/AWC NDS. DESIGN SHALL COMPLY WITH IBC CHAPTER 23 AND ANSII/AWC NDS.

NOTE:
1. HARDY TIE BACK ANCHOR FABRICATOR IS TOBIN STEEL, LA CITY FABRICATOR LICENSE #975 ICC-ESR 1822. IAPMO ER# 461
2. HARDY TIE BACK ANCHOR DEVICE HAS BEEN TESTED BY CERTIFIED TESTING AGENCY TO MEET OR EXCEED OSHA AND CALOSHA REQUIREMENTS.
3. HTB-ALT ANCHOR REQUIRES A ROUGH OPENING OF 14 1/2" x 19".



IAPMO ER# 461

2020 L.A. CITY RESIDENTIAL CODE (LARC)
2020 L.A. CITY BUILDING CODE (LABC)

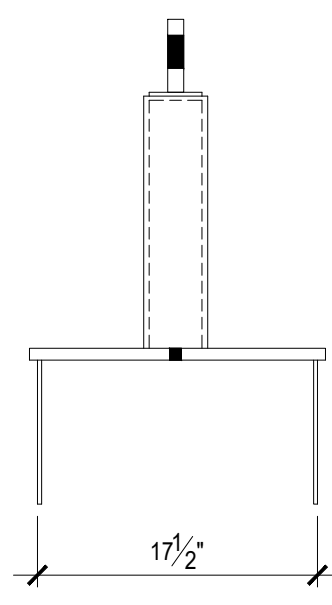

HTB-ALT-T24

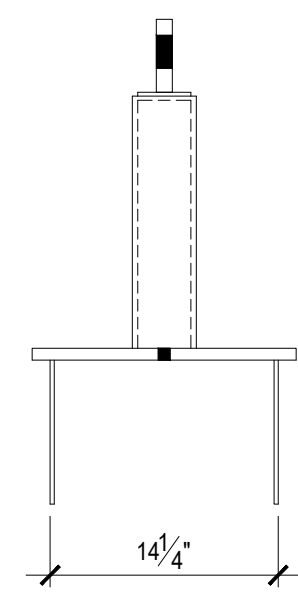

HTB-ALT-24

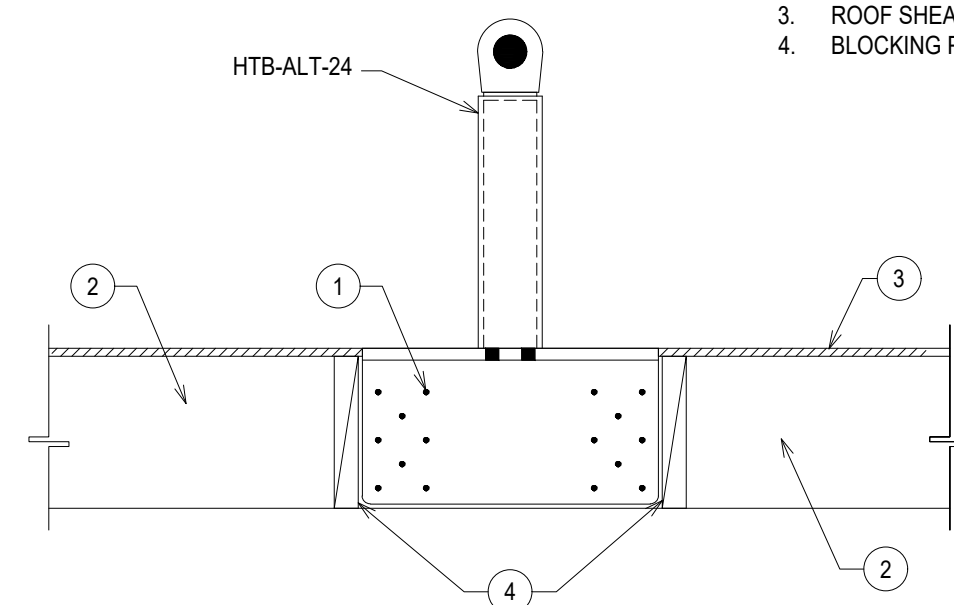

SECTION A-A
HTB ASSEMBLY

KEYNOTES LEGEND

- SDS 1/4" X 3" PER SCHEDULE
- BEAM PER EOR
- ROOF SHEATHING PER EOR
- BLOCKING PER EOR

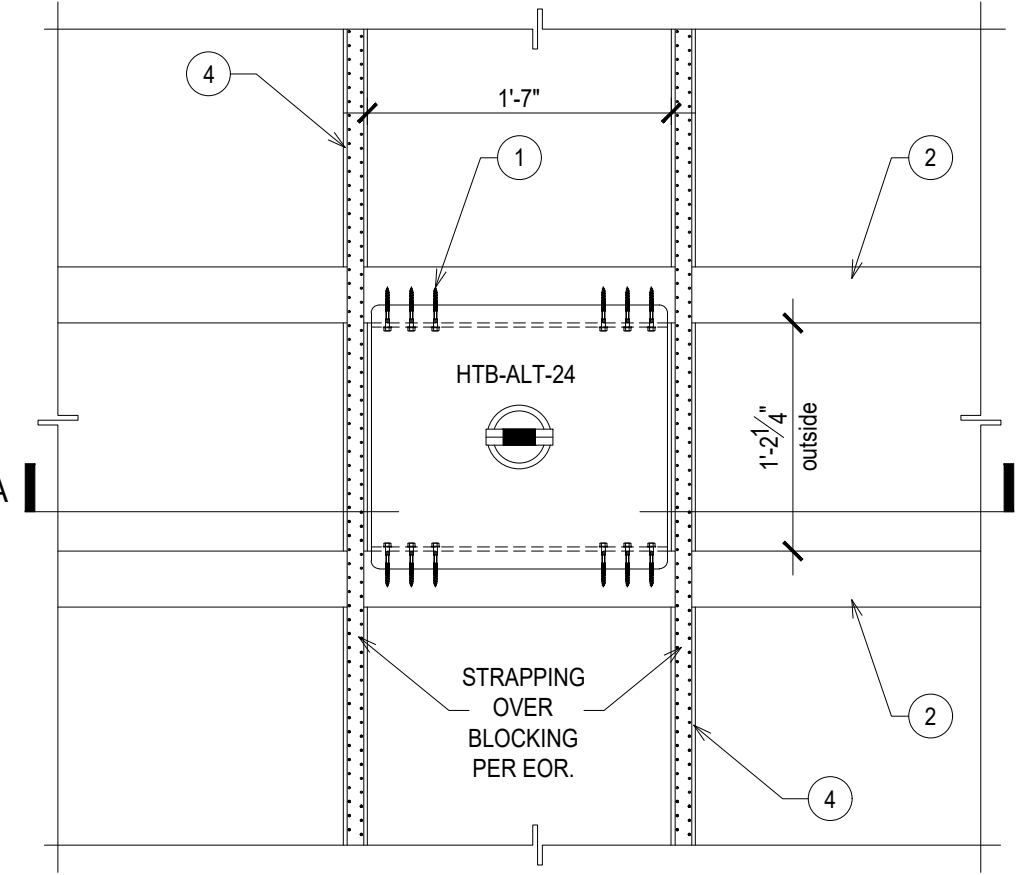

HTB LAYOUT DETAIL W/ 2x FRAMING 4

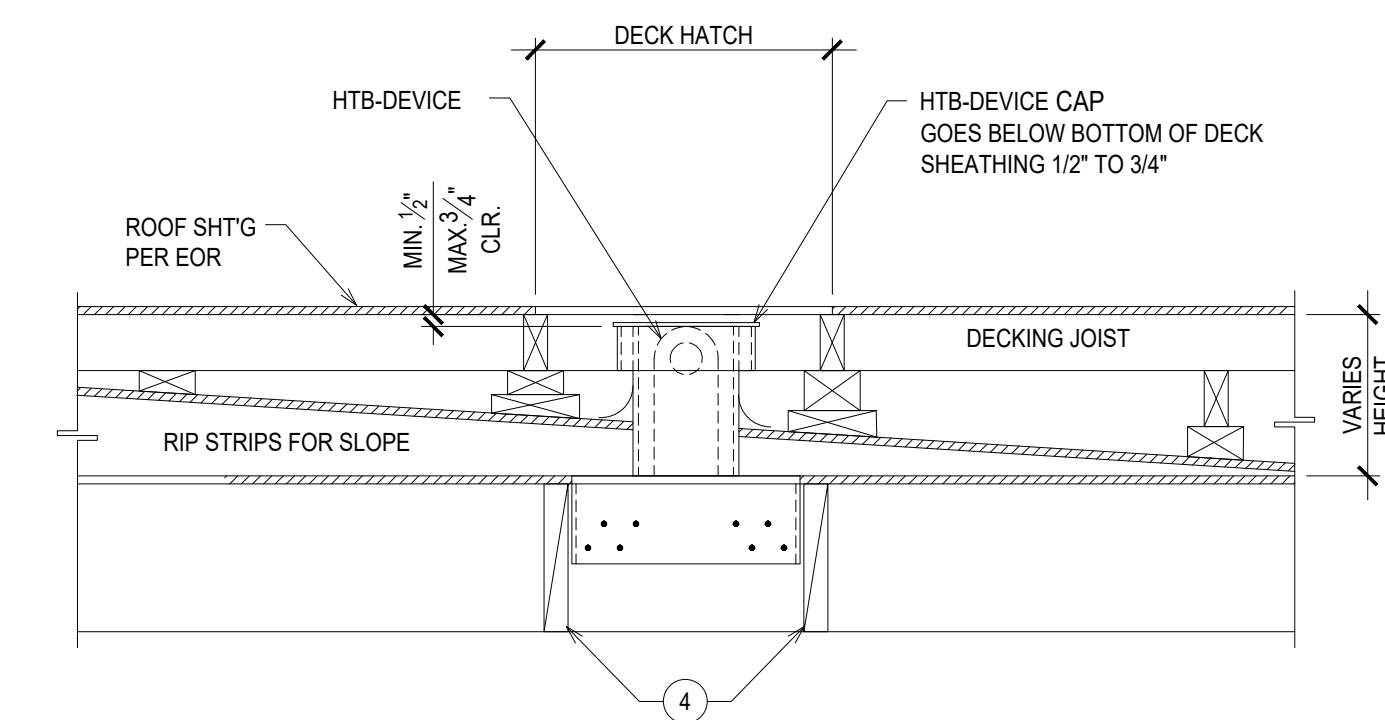

HTB-ALT-CM LAYOUT BELOW ROOF DECK ABV RIP STOPS 3

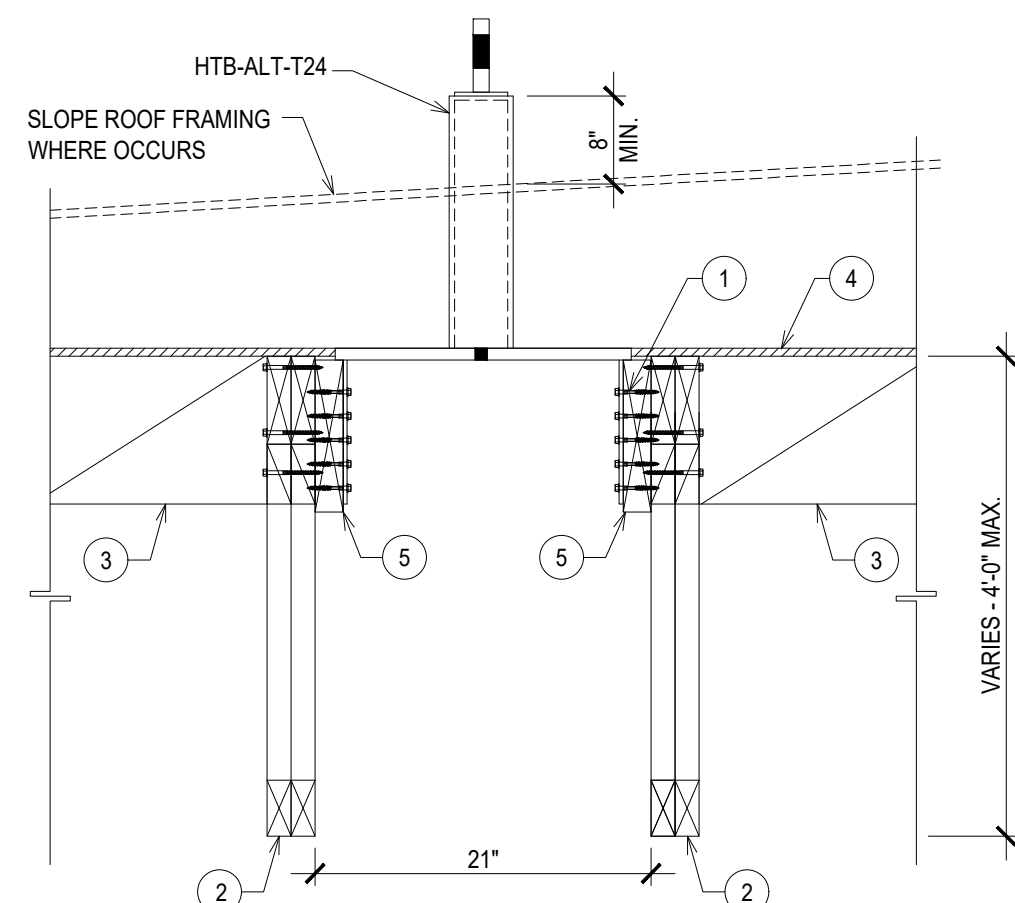

SECTION B-B

KEYNOTES LEGEND

- SDS 1/4" X 3" PER SCHEDULE
- STRUCTURAL SUPPORT DBL TRUSS BY EOR, 2 PLY MIN.
- BLK'G W/ STRAP PER EOR
- ROOF SHEATHING PER EOR
- 1 3/4" ENGINEERED BEAM ATTACHED TO DBL TRUSS PER EOR - CENTERED TO HTB

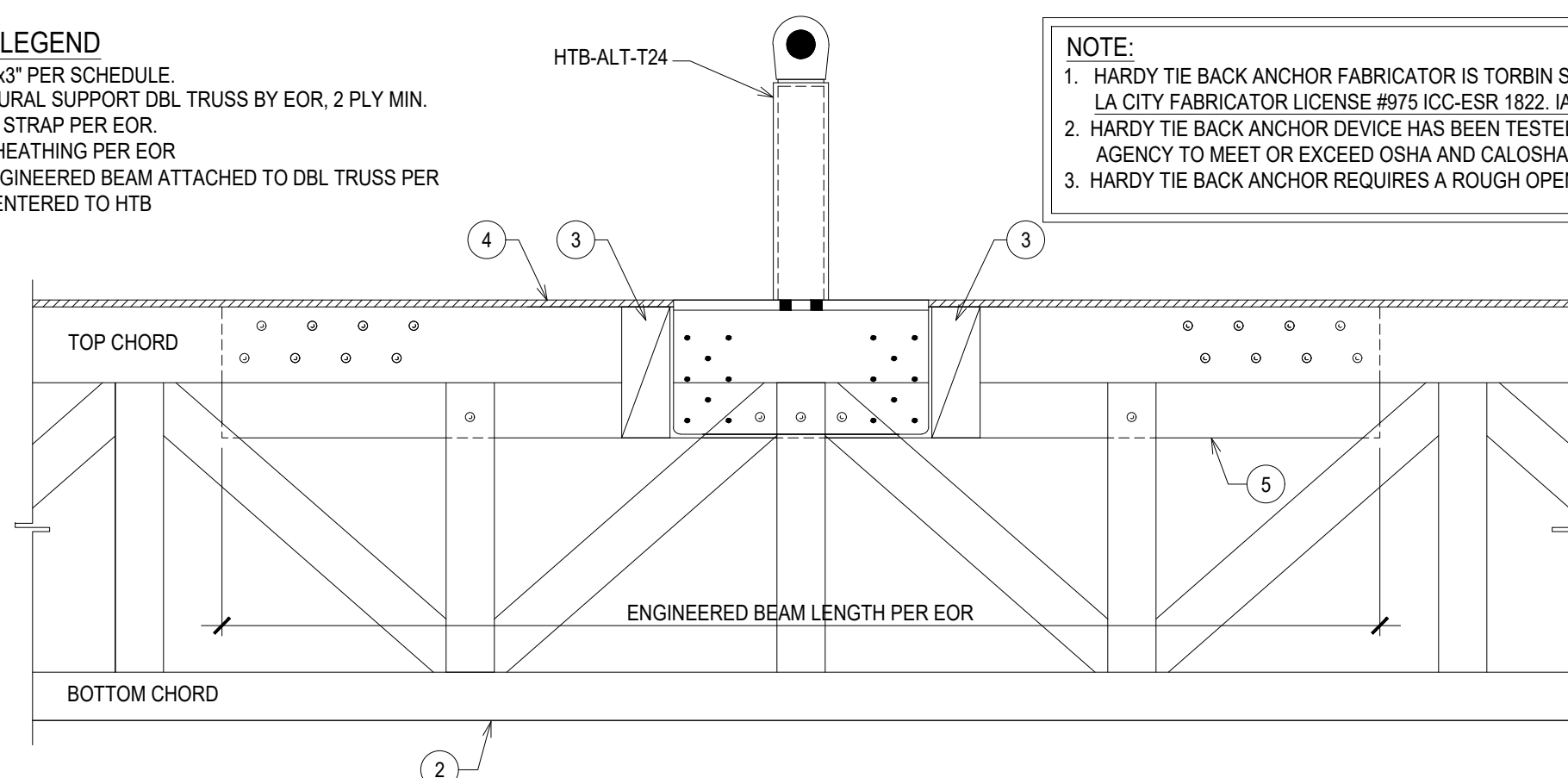

SECTION A-A

NOTE:
1. HARDY TIE BACK ANCHOR FABRICATOR IS TORBIN STEEL, LA CITY FABRICATOR LICENSE #975 ICC-ESR 1822. IAPMO ER# 461
2. HARDY TIE BACK ANCHOR DEVICE HAS BEEN TESTED BY CERTIFIED TESTING AGENCY TO MEET OR EXCEED OSHA AND CALOSHA REQUIREMENTS.
3. HARDY TIE BACK ANCHOR REQUIRES A ROUGH OPENING OF 18" x 19".

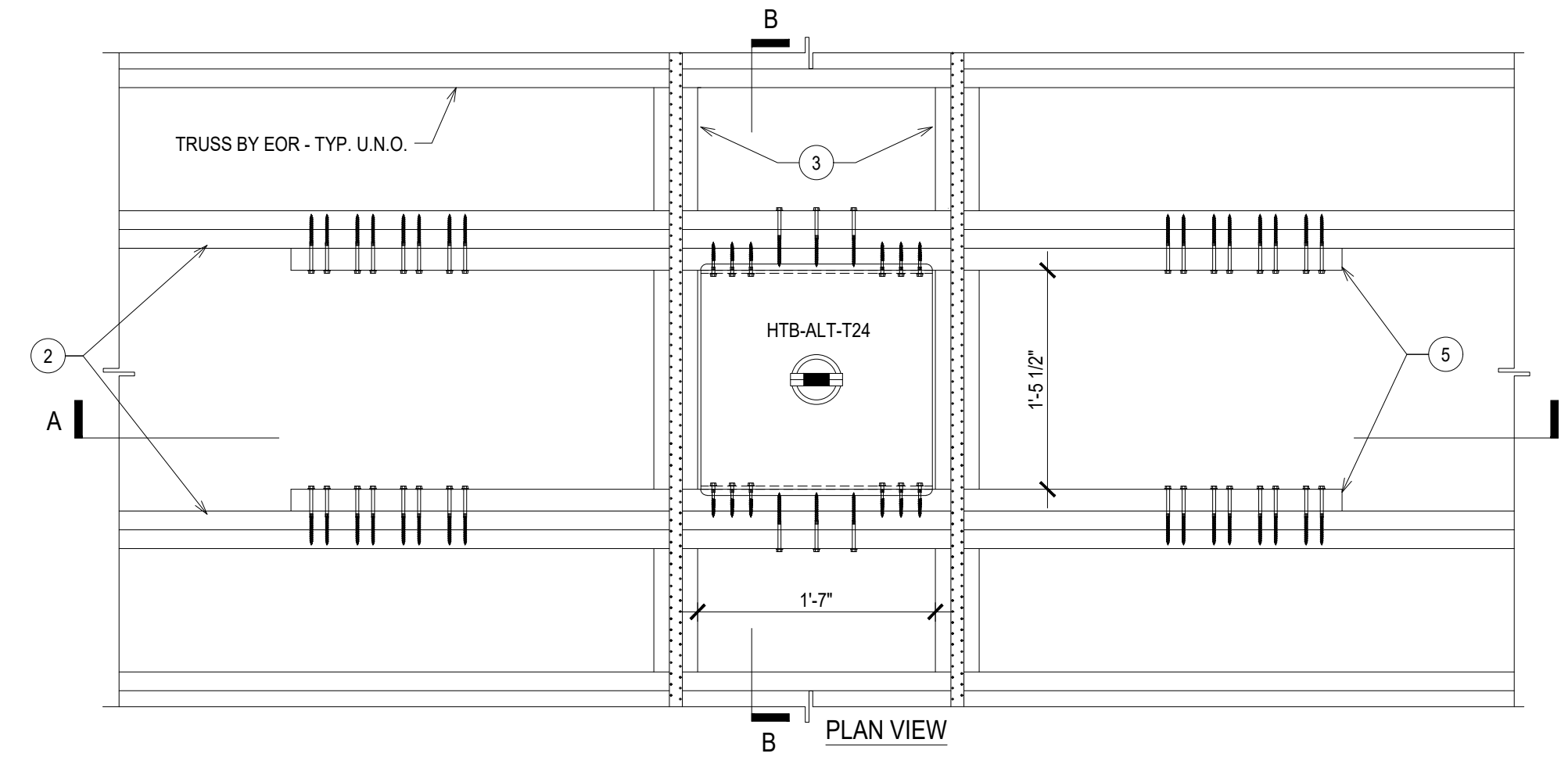

HTB-ALT LAYOUT DETAIL W/ WOOD TRUSS 2

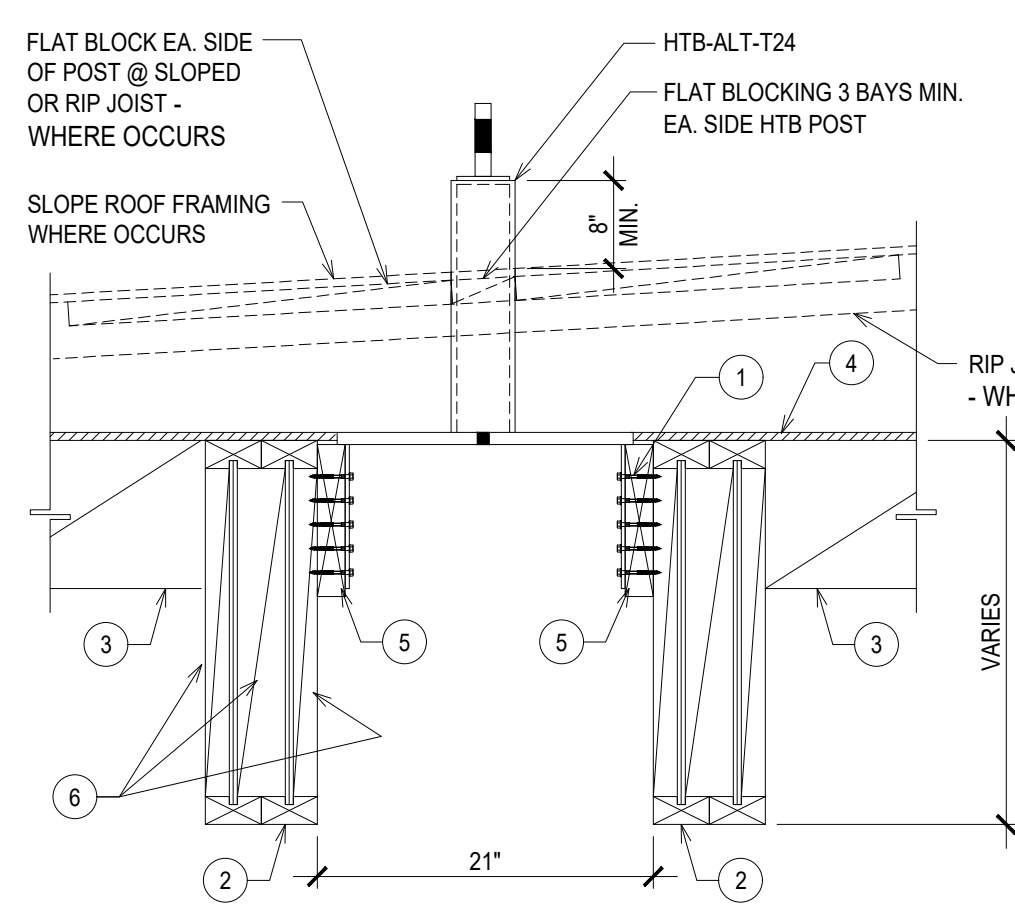

SECTION B-B

KEYNOTES LEGEND

- SDS 1/4" X 3" PER SCHEDULE
- I-JOIST BY EOR, 2 PLY MIN.
- BLK'G W/ STRAP PER EOR (MIN. 2X BLKG)
- ROOF SHEATHING PER EOR
- 1 3/4" ENGINEERED BEAM ATTACHED TO I-JOIST PER EOR - CENTERED TO HTB
- I-JOIST FILLER PER EOR

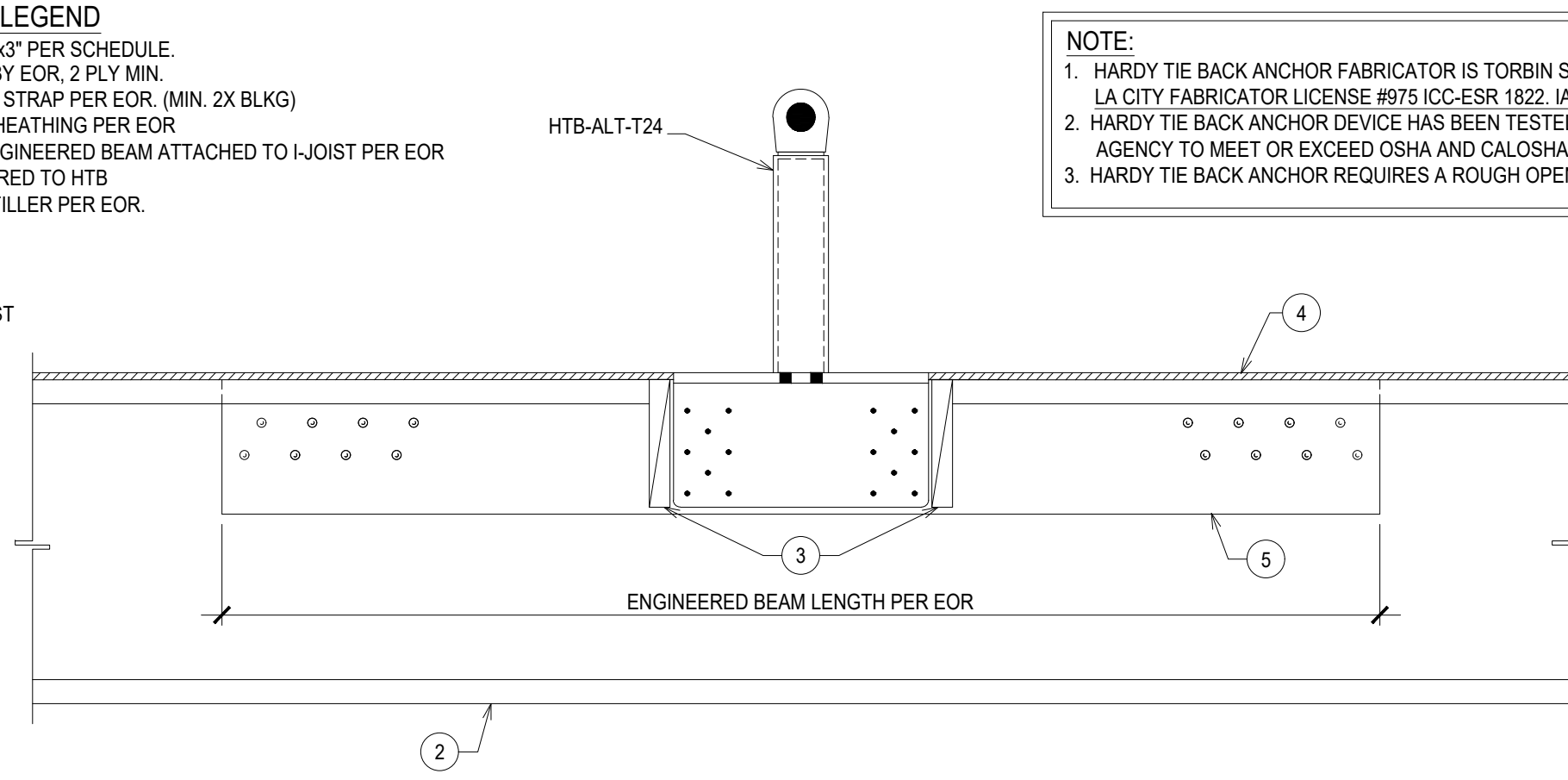

SECTION A-A

NOTE:
1. HARDY TIE BACK ANCHOR FABRICATOR IS TORBIN STEEL, LA CITY FABRICATOR LICENSE #975 ICC-ESR 1822. IAPMO ER# 461
2. HARDY TIE BACK ANCHOR DEVICE HAS BEEN TESTED BY CERTIFIED TESTING AGENCY TO MEET OR EXCEED OSHA AND CALOSHA REQUIREMENTS.
3. HARDY TIE BACK ANCHOR REQUIRES A ROUGH OPENING OF 18" x 19".

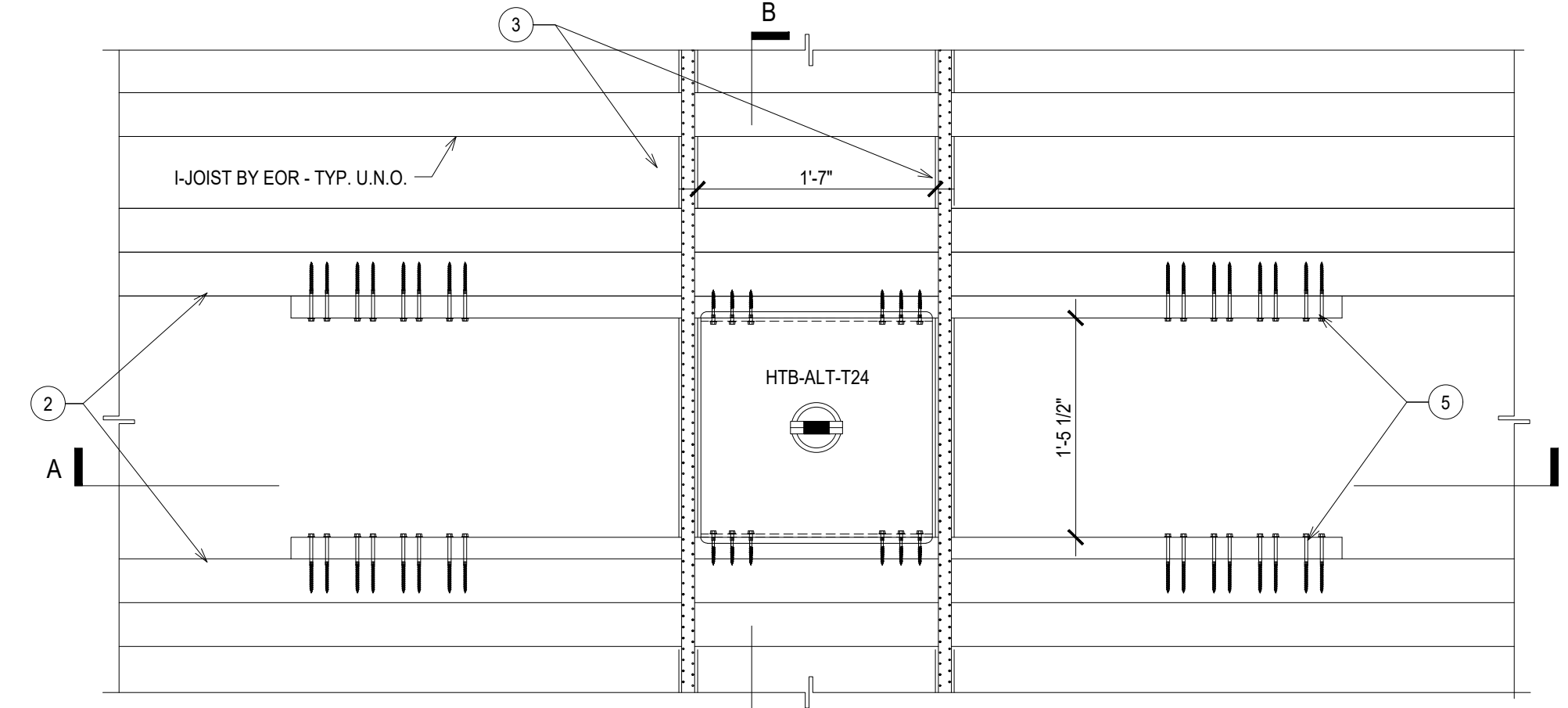

HTB-ALT LAYOUT DETAIL W/ I-JOIST 1

DETAILS FOR REFERANCE--EOR TO DESIGN STRUCTURAL ELEMENTS-BEAMS, TRUSSES, BLOCKING, STRAPPING, ETC.

HARDY TIE BACK ANCHOR DEVICE HTB DETAIL SHEET



ISSUE/REVISION	DATE
REV.#2	5-27-22
REV.#3	10-24-22
---	---

JOB NO. ---

SCALE: NOT TO SCALE
DATE: SEPTEMBER 8, 2020
DRAWING NUMBER

HTB.ALT
SHEET 1 OF 1